

ACCIO 8 x 4



BUILDING AND SERVICING  
AUSTRALIA FOR OVER 40 YEARS

IVECO

# ACCO 8 x 4



## ERGONOMICS

- LARGE NON-SLIP SELF-CLEANING CAB STEPS
- THREE POINT CONTACT FOR CAB INGRESS AND EGRESS
- INTERNAL CAB LAYOUT READY FOR APPLICATION SPECIFIC FIT-OUT
- OPTIMAL DRIVER FIELD OF VISION



## STRENGTH

- OVER 40 YEARS OF OPERATING IN THE MOST DEMANDING APPLICATIONS TO MEET TODAY'S REQUIREMENTS
  - SOLID STEEL CAB CONSTRUCTION
  - HEAVY DUTY CAB TRIM



## PRODUCTIVITY

- LOW TARE WEIGHT
- LOW CAB HEIGHT
- LONG LIFE CYCLE



## VERSATILITY

- APPLICATION SPECIFIC CHASSIS CONFIGURATIONS
  - CHOICE OF SUSPENSION CONFIGURATIONS FOR LIGHT WEIGHT AND HEAVY DUTY APPLICATIONS
  - ULTRA LIGHT WEIGHT COMPONENTS AVAILABLE



## AUSTRALIAN MADE

- DESIGNED, ENGINEERED AND MANUFACTURED IN AUSTRALIA
- CONSTRUCTED WITH LOCALLY SOURCED CONTENT



## P E R F O R M A N C E

CUMMINS 8.9 LITRE ISL EURO 5 ENGINE  
UP TO 340HP AND 1106 LB FT OF TORQUE

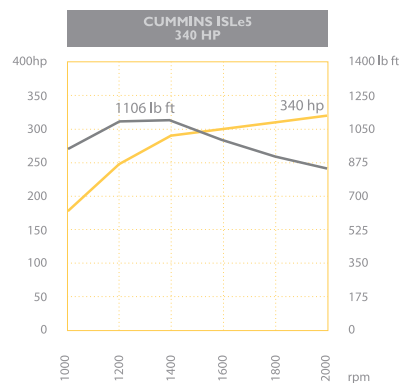
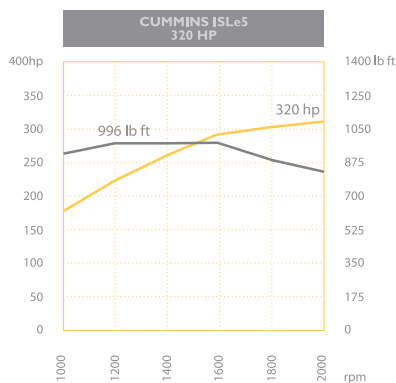

**ENGINE** Cummins ISL Euro 5 (ADR 80/03)

|                             |  |
|-----------------------------|--|
| <b>Maximum Output</b>       | 320hp/239kW @ 2100rpm  |
| <b>Maximum Torque</b>       | 996lb ft/1350Nm @ 1300rpm  |
| <b>Emissions Technology</b> | Selective Catalytic Reduction (SCR)  |
| <b>Air Filter</b>           | Donaldson Radial Seal 381mm dry element air cleaner with safety element              |
| <b>Exhaust</b>              | Vertical exhaust catalyst on RHS with perforated heat shield<br>Engine exhaust brake |

|                                |  |
|--------------------------------|--|
| <b>Total Displacement</b>      | 8.9 litres   |
| <b>Optional Engine Ratings</b> | 340hp/254kW @ 2100rpm & 1106 lb ft/1500Nm @ 1300rpm                                      |
| <b>Optional</b>                | Centrifuge oil spinner<br>Underslung exhaust for front lift compactors (5.84m wheelbase) |



# PRODUCTIVITY & VERSATILITY

CLASS LEADING LOW TARE WEIGHT

CHOICE OF SUSPENSION CONFIGURATIONS FOR LIGHT WEIGHT AND  
HEAVY DUTY APPLICATIONS  
SOLID STEEL CAB CONSTRUCTION  
HEAVY DUTY CAB TRIM



# WARRANTY

24 MONTHS\* / 500,000 KM / 6,000 HOURS / 100% PARTS AND LABOUR

This warranty commences on the earlier of the date of delivery of the truck to the Purchaser or the date of registration of the Vehicle.  
This warranty ends on the earliest of the expiry of the duration, kilometres or hours.

# Acco Vehicles used off highway for 10% or more of total usage by kilometres will be covered by a 12 month duration warranty only.  
Terms and Conditions apply, please see [www.iveco.com.au](http://www.iveco.com.au) for further details.

# ACCO 8 x 4

## CHASSIS DIMENSIONS (mm)

| WB              | AF   | L    | Turning Circle* |
|-----------------|------|------|-----------------|
| 5100 (Agitator) | 1800 | 8413 | 19822           |
| 5100 (Agitator) | 3000 | 9613 | 19822           |
| 5840            | 2100 | 9453 | 22061           |

\*For unladen cab-chassis. For wall-to-wall turning circle add 1740 mm. Refer to Bodybuilder diagrams for fuel tank lengths, locations and further details.

## MASS RATINGS

- GVM 30 tonnes
- GCM 30 tonnes
- Chassis mass front 5.7 tonnes\*
- Chassis mass rear 2.2 tonnes\*
- Chassis mass total 7.9 tonnes\*

\*Chassis with oil and coolant, but no fuel, spare wheel or tyre. All weights calculated based on 5.1m wheelbase Agitator spec. (All weights and measurements are approximate only).

## FRONT AXLE & SUSPENSION

- Meritor FG941 & FG943

**Type:** Forged steel I-beam with alloy hubs (agitator)

**Capacity:** 13.2 tonnes

**Optional:** Hendrickson Steertek axle with Airtek suspension, convolute leaf spring and shock absorbers with drum brakes

**Capacity:** 13.2 tonnes

**Suspension Type:** Heavy duty multi leaf springs, load share

**Capacity:** 13.4 tonnes

## REAR AXLE & SUSPENSION

- Meritor RT40-I45G (compactor)
- Meritor RT40-I45GA with aluminium differential carrier (agitator)
- Alloy hubs (agitator), cast hubs (compactor)

**Capacity:** 18.1 tonnes

**Ratio:** 6.14

**Optional:** Driver controlled differential lock (not available with RT40-I45GA)

**Suspension Type:** Hendrickson Haulmax HMX460 (rubber block)

**Capacity:** 20.8 tonnes

**Optional:** Hendrickson Primaax PAX462 (Air)

**Capacity:** 20.0 tonnes

**Optional:** Hendrickson HAS460 (Air) (not available with Airtek)

**Capacity:** 18.0 tonnes

## BRAKES

**Type:** 2-circuit air system

**Front & Rear:** Drum brakes with automatic slack adjusters, park brake acting on second steer and rear wheels, brake exhaust silencer and Centrifuse\* brake drums (agitator) and cast brake drums (compactor)

- Bendix 4 channel ABS with Active Traction Control (ATC)
- Bendix air dryer
- Steel air tanks

**Optional:** Electronic stability control (ESC) (only available on agitator spec)

- Aluminium air tanks

\*or different brand, equivalent model

## STEERING

- Sheppard M110 & M100 power-assisted with gear driven pump, adjustable steering column and 470mm steering wheel

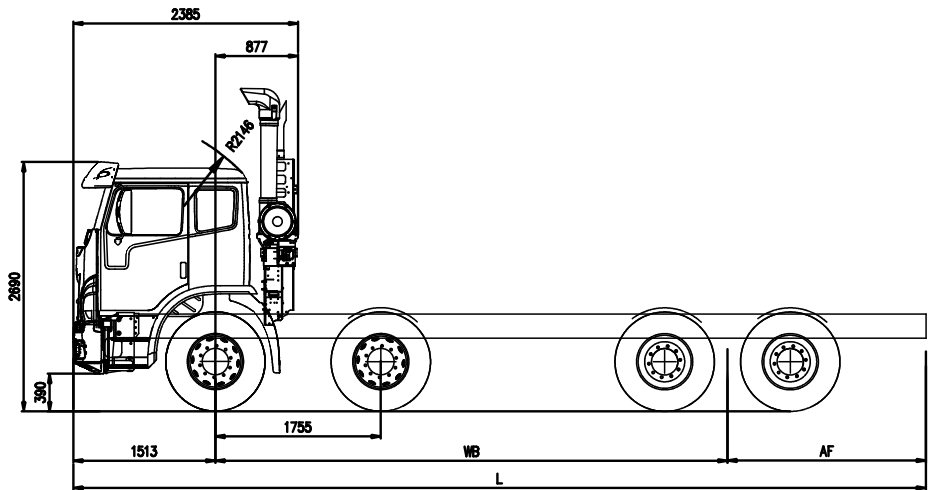

## FUEL SYSTEM

- 1 x 285 litre square alloy fuel tank
- 1 x 27 litre AdBlue tank
- Fuel Pro fuel filter

## TRANSMISSION

- Allison Gen 5 3200 series 6 speed automatic with external transmission cooler
- PowAuto PA38 (1.16:1) 650Nm hot shift transmission mounted PTO with mounting support bracket

## CHASSIS

**Type:** 257x89x8mm parallel-section high tensile steel channel

- Heavy duty centrally mounted front towing pin
- Square end of frame
- Three piece steel bumper
- FUPS
- Reverse buzzer

**Optional:** Full C channel reinforcement

## ELECTRICAL SYSTEM

**Type:** 12 Volt

**Batteries:** 3 x N50 – 70A

**Optional:** 3 x N70 – 90A

**Alternator:** 12 Volt 170A 2 pole isolation switch

## WHEELS & TYRES

**Wheels:** 8.25DC x 22.5 10-stud 335mm PCD steel (compactor)

8.25DC x 22.5 10-stud 285mm PCD alloy (agitator)

**Front tyres:** Dunlop SP350\* I1R22.5

**Rear:** Dunlop SP431A\* I1R22.5

**Optional:** Alcoa\* 8.25DC x 22.5 Durabrite finish

- Spare wheel carrier (supplied loose)
- Spare rim
- Alternative tyre sizes, brands and tread patterns available

\*or different brand, equivalent model

## COOLING SYSTEM

- Radiator frontal area: 783in<sup>2</sup>
- Charge air cooler frontal area: 622in<sup>2</sup>
- Supplementary cooling fan (compactor)

## DRIVELINE

- Spicer 1710 Series main driveshaft
- Spicer 1710 Series inter-axle shaft

## CAB CONSTRUCTION

- 2180mm wide cab with zinc-coated outer panels and Electrophoretic deposited steel cab with hydraulic lift
- Four point cab mounting system with rubber block front and air springs dampers rear

## CAB FEATURES

- Fully adjustable ISRI air suspension driver's seat with integrated lap sash seat belt and adjustable lumbar support
- Fixed ISRI passenger seat with lap sash seat belt
- Heavy duty trim
- Heavy duty radiator guard and stone shield
- Headlight protection grid
- Radio/CD MP3 player with Bluetooth
- Heated motorised mirrors
- 12 volt accessory socket
- Electric windows
- Electric or air horn
- Drink bottle holder
- In-cab body builder electrical and air connection
- Park brake alarm - horn alert
- Optional:** Air suspended single passenger seat
- Fixed passenger bench seat (Drink bottle holder not available)
- LED rear tail lights
- Rotating roof light
- Sunvisor
- Variable pitch reverse buzzer
- Fire extinguisher
- Supplementary cooling fan (agitator)
- Overhead console

# IVECO