

POWERSTAR 7800



BUILT TOUGH FOR AUSTRALIA

IVECO

# POWERSTAR 7800



## CAPABILITY

UP TO 140 TONNE GCM, 600HP AND 18 SPEED EATON ROADRANGER, SO NO MATTER WHAT YOU'RE HAULING THE 7800 HAS THE TOOLS TO GET IT DONE



## COMFORT & ERGONOMICS

SPACIOUS 56 INCH FULLY INTEGRATED SLEEPER CAB WITH NUMEROUS STORAGE COMPARTMENTS. ISRI AIR SUSPENDED DRIVERS SEAT



## HANDLING

IVECO CANTILEVER SUSPENSION PROVIDES RELIABILITY AND HANDLING IN OFF HIGHWAY APPLICATION. SUPERIOR WHEEL CUT ANGLE MAKES TURNING A BREEZE



## AUSTRALIAN MADE

DESIGNED AND BUILT HERE IN AUSTRALIA TO ENDURE HARSH CONDITIONS, THE POWERSTAR 7800 IS BORN TO DO THE TOUGH STUFF



## PRODUCTIVITY

SET FORWARD FRONT AXLE TO MAXIMISE LOAD CAPACITIES. ENLARGED ENGINE COOLING PACKAGE TO ENSURE YOU GET THE JOB DONE



## PERFORMANCE

CUMMINS 15 LITRE ISX OR SIGNATURE ENGINES

UP TO 600HP AND 2050 LB FT OF TORQUE

ENGINE BRAKE PERFORMANCE OF 600 RETARDING HORSEPOWER AT 2100RPM

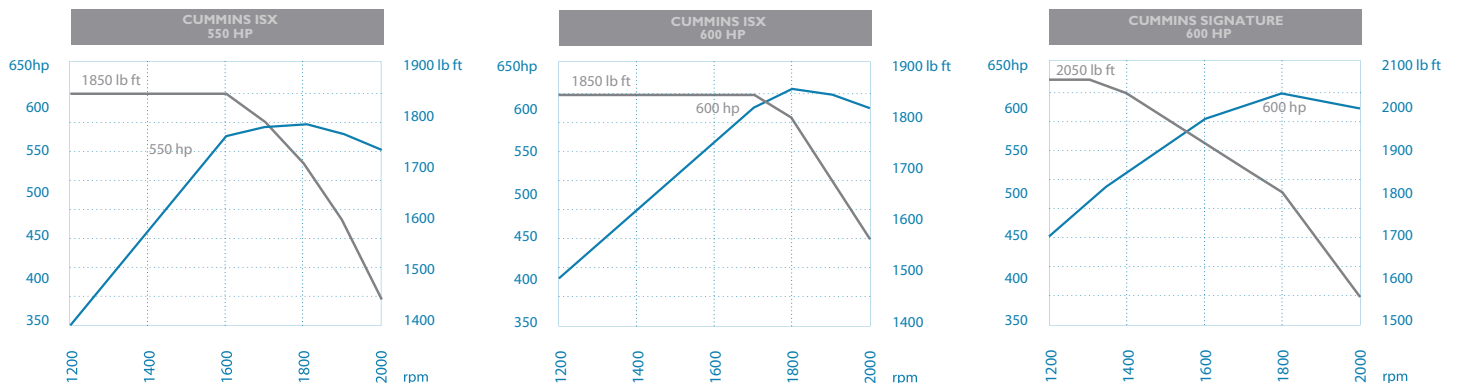

**ENGINE** Cummins 15-Litre 6 cylinder ISX (ADR 80/03)

<b>Maximum Output</b>	550hp/410kW	<b>Total Displacement</b>	14.9 litres
<b>Maximum Torque</b>	1850lb ft/2508Nm @ 1200rpm	<b>Optional Engine Ratings</b>	ISX 600hp/447kW & 1850lb ft/2508Nm Signature 600hp/447kW & 2050lb ft/2770Nm
<b>Emissions Technology</b>	Exhaust Gas Recirculation		

Two dry-element air cleaners (11") with two precleaners. Single, vertical gantry mounted Diesel Particulate Filter (DPF) on LHS



# COMFORT & ERGONOMICS

NEW DASHBOARD WITH ERGONOMICALLY POSITIONED,  
EASY-TO-REACH CONTROLS

THREE SLEEPER CAB VERSIONS  
MECHANICAL CANTILEVER REAR SUSPENSION  
SUPERIOR OFF HIGHWAY COMFORT



# POWERSTAR 7800

## CHASSIS DIMENSIONS (mm)

<b>WB</b>	6000	<b>AF</b>	1473
<b>GC (Front)</b>	260	<b>GC (Rear)</b>	200

## CAB DIMENSIONS (mm)

	<b>H</b>	<b>H (aero kit)</b>
Medium roof sleeper	3713	4077

## SUSPENSION (mm)

<b>B</b>	<b>C</b>	<b>D Laden</b>	<b>D Unladen</b>	<b>E</b>
699	702	1053	1101	80

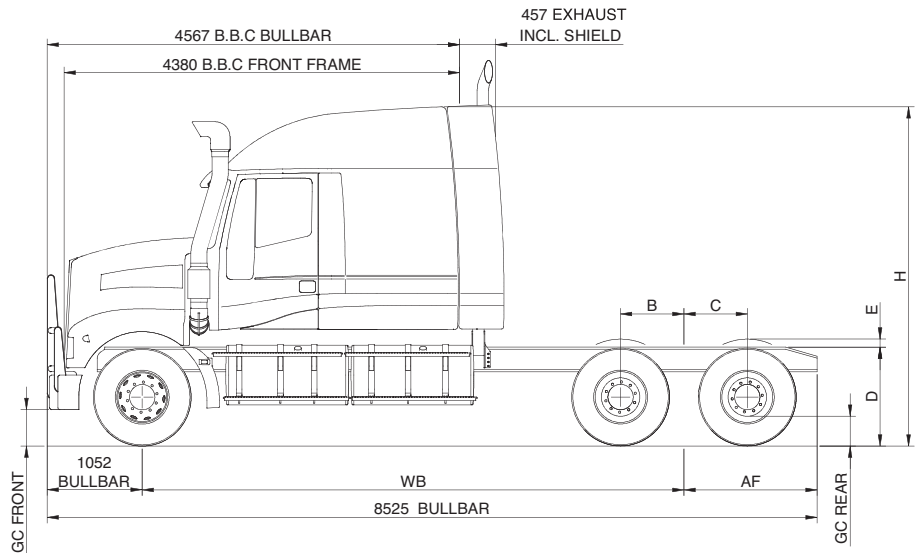

## MASS RATINGS

- GVM 28.2 tonnes
- GCM 140.0 tonnes
- Chassis mass front 5.8 tonnes\*
- Chassis mass rear 5.4 tonnes\*
- Chassis mass total 11.2 tonnes\*

\*Chassis with oil and coolant, but no fuel, spare wheel or tyre, no driver or passenger. Weights may vary pending wheel and sleeper cab options

## CLUTCH

- Eaton Easy Pedal Advantage twin plate
- Hydraulic and air assist

**Diameter:** 394mm

## FRONT AXLE & SUSPENSION

- Meritor MFS

**Axle Type:** Forged steel I-beam

**Capacity:** 7.3 tonnes

**Suspension Type:** Multileaf springs double acting telescopic shock absorbers

**Capacity:** 7.5 tonnes

## REAR AXLE & SUSPENSION

- Meritor RT52-185

**Capacity:** 20.9 tonnes

**Ratio:** 4.56 or 4.89

- Driver controlled differential locks on rear/rear only

**Suspension Type:** IVECO Cantilever

**Capacity:** 22.0 tonnes

## BRAKES

**Type:** 2-circuit air system

**Front:** Meritor S-Cam 419mm diameter x 152mm drum brakes with automatic slack adjusters

**Rear:** Meritor S-Cam 419mm diameter x 178mm drum brakes with automatic slack adjusters

- Air dryer Turbo 2000
- Air connections at back of cab & rear of frame
- Wabco E 4-channel ABS with ASR
- Trailer ABS facility

## STEERING

- Sheppard M110 power-assisted with gear-driven pump
- 460mm diameter adjustable steering wheel with pneumatic floor release switch

## FUEL SYSTEM

- 4 x 450 litre aluminium round tanks

## TRANSMISSION

- Eaton Roadranger RTLO-20918B 18-speed overdrive

**Optional:** Eaton Roadranger RTLO-22918B 18-speed overdrive

## CHASSIS

**Type:** 273 x 89 x 9.5mm parallel-section high-tensile steel channel with full length C-channel reinforcement 251 x 73 x 6.35mm

- Tapered rear of frame with fifth wheel mounting angles
- Without front bumper (ready for aftermarket bullbar fitment) with FUPS

**Optional:** Polished four post aluminium bullbar

## ELECTRICAL SYSTEM

**Type:** 24-Volt

- Multiplex computerised CANBUS integrated wiring and systems control network with centralised colour display, controls and diagnostics

**Batteries:** 4 x 620 amps

**Alternator:** 24V, 140 amps

- Semi-trailer HD ISO 7-pin socket

## WHEELS & TYRES

**Wheels:** Alcoa® 8.25DC x 22.5

10-stud 285mm PCD alloy

**Front tyres:** Goodyear® 385/65R22.5 LHS II

**Rear:** Goodyear® 11R22.5 G367

**Optional:** Alcoa® 8.25DC x 22.5

- Plain or Durabright finish
- Cast six spoke spider wheels

\*or different brand, equivalent model.

## COOLING SYSTEM

- Radiator frontal area: 1930in<sup>2</sup>
- Charge air cooler frontal area: 94lin<sup>2</sup>

## DRIVELINE

- Dana SPL-250 Driveshafts

## CAB FEATURES

- IVECO Integrated 56" Comfort Sleeper Cab including inner spring mattress (1950mm x 800mm x 200mm)
- Privacy curtains for bunk area, lockers below bunk, external stowage lockers under sleeper (both sides), stowage lockers in overhead console above windscreen and fridge provision under bunk
- Five point cab mounting system with air suspension and dampers at rear.
- Optional:** Aerodynamic roof deflectors and cab side extenders
- Premium Sleeper Cab – includes bunk and cabinets
- Executive Sleeper Cab – includes bunk, cabinets, LCD flat screen TV/DVD and Engel fridge

## SEATS

- Fully adjustable ISRI self levelling air suspended driver's seat with headrest and armrest, lumbar support, adjustable shock absorber and integrated lap sash seat belt
- Fixed ISRI passenger seat with integrated lap sash seat belt
- Optional:** ISRI Big Boy Driver Seat
- Leather driver and passenger seat
- ISRI air suspended passenger seat

# IVECO